



High Efficiency Inductor Based Step-Up Converter for White LEDs

Features

- Drives Up to Four LED's from a 3.2V Source
- Series Connected LED Diodes for Matched Light Output
- High Efficiency (all MOS), typically 90%
- Internal Thermal Shutdown
- Soft Start to Reduce Inrush Currents during Start-Up or from Shutdown
- 21V DMOS Switch
- 1.2MHz Switching Frequency
- Uses Low Profile 1mm Tall Inductors
- SC70 and ThinSOT Packages

Applications

- Cellular Phones
- PDA's , Handheld Computers
- Digital Cameras
- MP3 Players
- GPS Receivers
- Battery Powered LCD Displays

General Description

The ZD1937 is a constant frequency, current mode PWM, inductor based step-up (boost) converter especially designed to drive multiple white LED's in series. The LED current is regulated in this converter design so that all LED's have the same current and therefore have inherently matched light output. The converter design operates at high frequency (1.2MHz) operation so that a small, low profile inductor can be used as well a small value output integrating capacitor.

The ZD1937 is available in either a space saving SC70 package or the ThinSOT 5 pin package for very small board space applications

Ordering Information

Part Number	Temperature Range	Package Type
ZD1937CM5	0°C to +70°C	5-Pin TSOT-23
ZD1937CC6	0°C to +70°C	6-Pin SC70
ZD1937EM5	-40°C to +85°C	5-Pin TSOT-23
ZD1937EC6	-40°C to +85°C	6-Pin SC70

Please contact the factory for pricing and availability on Tape-on-Reel option.

Pin Configuration

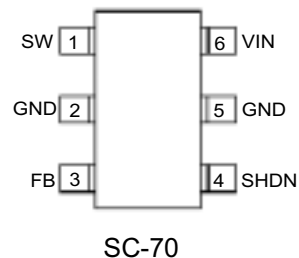
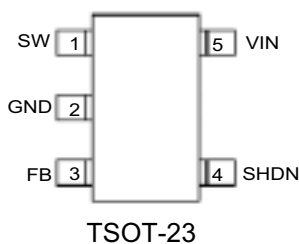

Typical Application

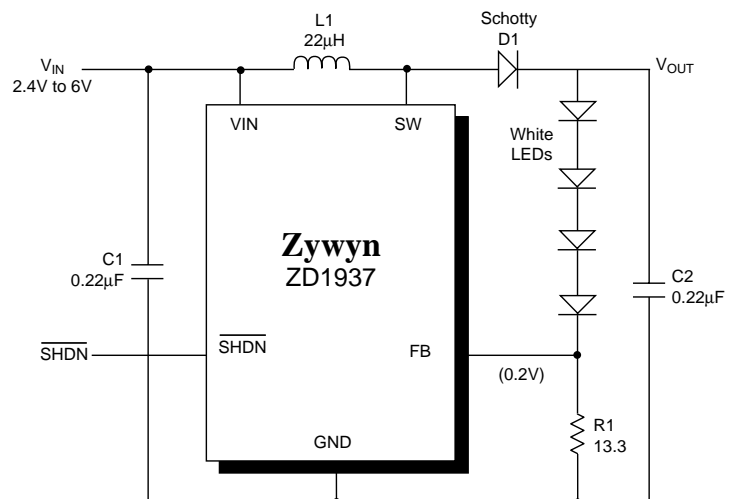

Absolute Maximum Ratings

These are stress ratings only and functional operation of the device at these ratings or any other above those indicated in the operation sections of the specifications is not implied. Exposure to absolute maximum rating conditions for extended periods of time may affect reliability.

Input Voltage, (V_{IN})	+9V
SW Voltage	+21V
FV Voltage	+9V
SHDN Voltage	+6V
Extended Commercial	
Operating Temperature	-40°C to +85°C
Maximum Junction Temperature	+125°C
Storage Temperature	-65°C to +150°C
Lead Temperature (Soldering, 10sec.)	300°C

Storage Considerations

Storage in a low humidity environment is preferred. Large high density plastic packages are moisture sensitive and should be stored in Dry Vapor Barrier Bags. Prior to usage, the parts should remain bagged and stored below 40°C and 60%RH. If the parts are removed from the bag, they should be used within 48 hours or stored in an environment at or below 20%RH. If the above conditions cannot be followed, the parts should be baked for four hours at 125°C in order to remove moisture prior to soldering. Zywyn ships product in Dry Vapor Barrier Bags with a humidity indicator card and desiccant pack. The humidity indicator should be below 30%RH. The information furnished by Zywyn has been carefully reviewed for accuracy and reliability. Its application or use, however, is solely the responsibility of the user. No responsibility of the use of this information become part of the terms and conditions of any subsequent sales agreement with Zywyn. Specifications are subject to change without no responsibility for any infringement of patents or other rights of third parties which may result from its use. No license or proprietary rights are granted by implication or otherwise under any patent or patent rights of Zywyn Corporation.

Electrical Characteristics

$T_A = +25^\circ\text{C}$, $V_{IN} = 3\text{V}$, SHDN = 3V; unless otherwise noted.

Parameter	Condition	Min	Typ	Max	Units
Min Operating Voltage		2.4			V
Max Operating Voltage				6	V
Feedback Voltage	$I_{sw} = 100\text{mA}$	0.181	0.2	0.219	mV
FB Pin Bias Current		10	45	100	nA
Supply Current	SHDN = 0V		1.9 0.1	2.5 1	mA μA
Switching Frequency		0.75	1	1.33	MHz
Maximum Duty Cycle		85	90		%
Switch Current Limit			320		mA
Switch Vds	$I_{sw} = 250\text{mA}$		350		mV
Switch Leakage Current	$V_{sw} = 5\text{V}$		0.01	5	μA
SHDN Voltage High (ON)		1.5			V
SHDN Voltage Low (OFF)				0.4	V
SHDN Pin Bias Current			65		μA

Block Diagram

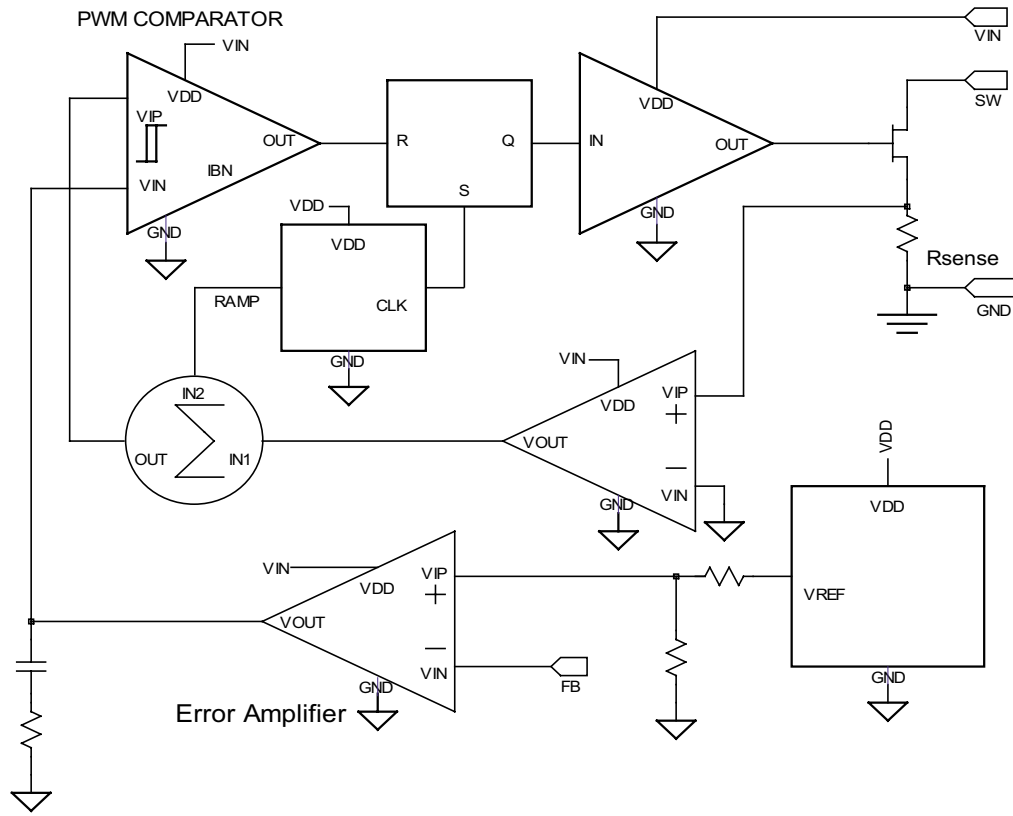

Pin Description

Pin Number	Pin Name	Pin Function
1	SW	Switch Pin. Connect inductor/diode here. Minimize trace area at this pin to reduce EMI.
2	GND	Ground Pin. Connect directly to local ground plane.
3	FB	Feedback Pin. Internally servos to 95mV. Connect cathode of lowest LED and resistor here. Calculate resistor value according to the formula: $R_{FB}=0.095/I_{LED}$.
4	SHDN	Shutdown Pin. Connect to 1.5V or higher to enable device (ON), 0.4V or lower to disable device (OFF).
5 (SC70 package)	GND	Ground Pin. Connect to Pin 2 and to local ground plane.
6 (SC70) 5 (TSOT-23)	VIN	Input Supply Pin. Must be locally bypassed with 1uF capacitor.